

CANDIDATE
NAME

CENTRE
NUMBER

--	--	--	--	--

CANDIDATE
NUMBER

--	--	--	--



PHYSICS

Paper 3 Practical Test

5054/32

May/June 2016

2 hours

Candidates answer on the Question Paper.

Additional Materials: As listed in the Confidential Instructions.

READ THESE INSTRUCTIONS FIRST

Write your Centre number, candidate number and name on all the work you hand in.

Write in dark blue or black pen.

You may use an HB pencil for any diagrams or graphs.

Do not use staples, paper clips, glue or correction fluid.

DO NOT WRITE IN ANY BARCODES.

Answer **all** questions.

For each of the questions in Section A, you will be allowed to work with the apparatus for a maximum of 20 minutes. For the question in Section B, you will be allowed to work with the apparatus for a maximum of 1 hour.

You are expected to record all your observations as soon as these observations are made.

An account of the method of carrying out the experiments is **not** required.

Electronic calculators may be used.

You may lose marks if you do not show your working or if you do not use appropriate units.

At the end of the examination, fasten all your work securely together.

The number of marks is given in brackets [] at the end of each question or part question.

For Examiner's Use	
1	
2	
3	
4	
Total	

This document consists of **12** printed pages.

Section A

Answer **all** questions in this section.

- 1 In this experiment, you will determine an accurate value for the mass of a 30 cm plastic ruler.

You have been provided with

- a 30 cm plastic ruler with a mm scale,
- a 10 g mass,
- a pivot (knife-edge).

- (a) Fig. 1.1 shows a 30 cm ruler of total length L .

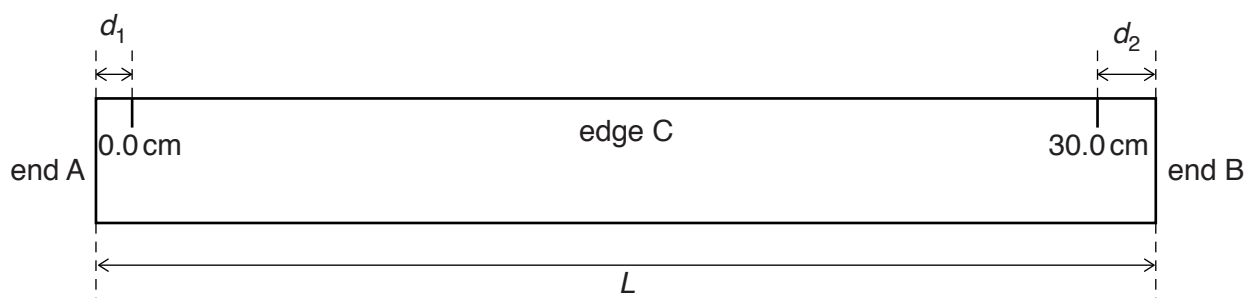

Fig. 1.1

At one end of the ruler there is a 'dead space' of length d_1 before the 0.0 cm mark and at the other end there is a 'dead space' of length d_2 after the 30.0 cm mark.

- (i) Place the ruler provided on Fig. 1.2.

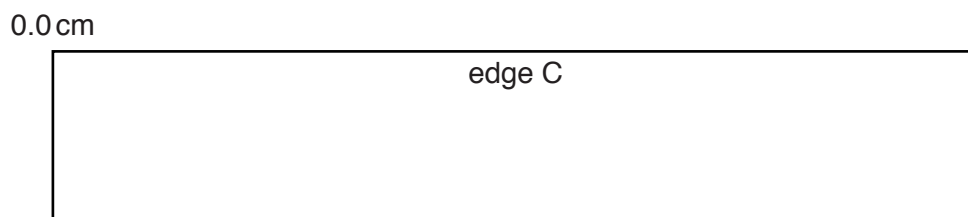

Fig. 1.2

Align the 0.0 cm mark and edge C of the ruler with the lines in the diagram. Draw a line on Fig. 1.2 to mark the position of end A of the ruler. Using Fig. 1.2, measure d_1 .

$$d_1 = \dots\dots\dots$$

- (ii) Using Fig. 1.3, repeat (a)(i) with end B and measure d_2 .

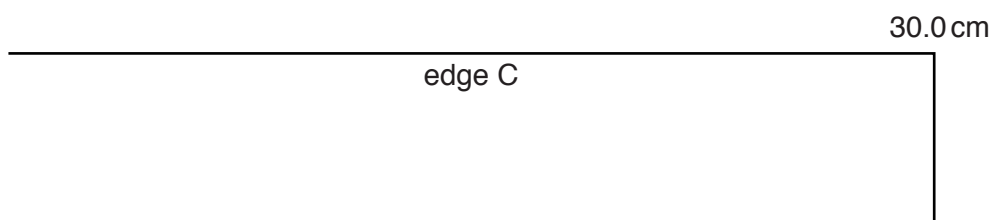

Fig. 1.3

$$d_2 = \dots\dots\dots$$

(iii) Calculate the total length L of the ruler.

$L = \dots\dots\dots$ [2]

(b) (i) Place the ruler on the pivot. Move the position of the ruler until it balances horizontally. Record the scale reading S_1 shown on the ruler at the position of the pivot.

$S_1 = \dots\dots\dots$

(ii) Place the 10g mass so that its outer edge is at the 30.0 cm mark on the ruler. Record the scale reading S_2 shown on the ruler at the position of the centre of the 10g mass.

$S_2 = \dots\dots\dots$

(iii) With the 10g mass position in (b)(ii), place the ruler on the pivot and move the position of the ruler until it balances horizontally. The arrangement is shown in Fig. 1.4.

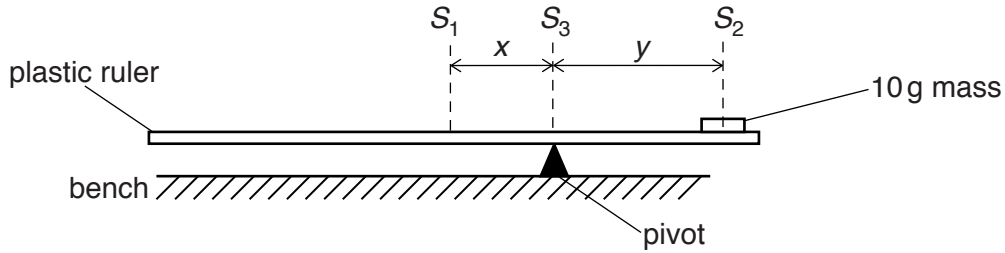

Fig. 1.4

Record the scale reading S_3 shown on the ruler at the pivot.

$S_3 = \dots\dots\dots$

(iv) Determine the distances x and y shown on Fig. 1.4.

$x = \dots\dots\dots$

$y = \dots\dots\dots$

[2]

(c) Calculate the mass M of the ruler using $M = \frac{10y}{x}$.

$M = \dots\dots\dots$ g [1]

[Total: 5]

[Turn over

2 In this experiment, you will investigate the oscillations of a metre rule with added masses.

You have been provided with

- a metre rule with a hole at the 10.0 cm mark,
- an optical pin in a cork,
- a stand, boss and clamp to hold the cork,
- two 100 g masses,
- Blu-tack,
- a stopwatch.

(a) The Supervisor has set up the apparatus as shown in Fig. 2.1.

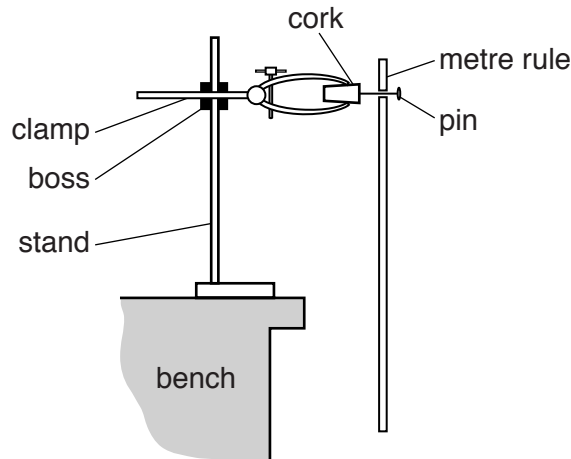

Fig. 2.1

Remove the metre rule from the pin. Use the Blu-tack to attach the masses to the rule, at the 100 cm end. The masses should be attached on each side of the rule and the edge of the masses should be level with the 100 cm mark. A front view of the arrangement is shown in Fig. 2.2 and a side view in Fig. 2.3. Press the masses firmly to the rule.

Determine the distance d_1 from the centre of the hole at the 10.0 cm mark to the centre of the masses.

$d_1 = \dots\dots\dots [1]$

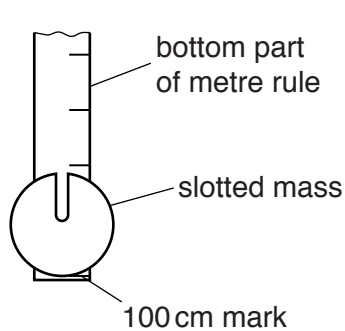

Fig. 2.2 (front view)

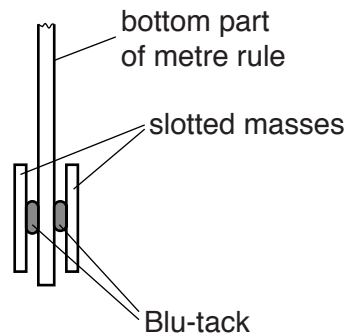

Fig. 2.3 (side view)

- (b) Replace the metre rule on the pin using the hole at the 10 cm mark. When the rule is displaced a small distance to the left and released, it moves to the right and then back to the left. This is one complete oscillation as shown in Fig. 2.4.

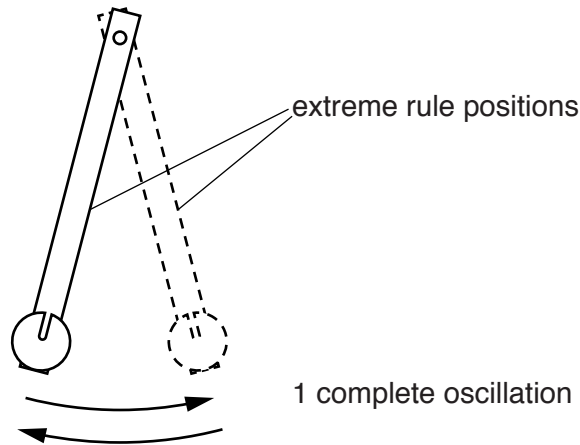

Fig. 2.4

- (i) The time for 10 complete oscillations is t_1 . Take measurements to determine an accurate value of t_1 .

$$t_1 = \dots\dots\dots$$

- (ii) Calculate the time T_1 for one complete oscillation. Give your answer to a suitable number of significant figures.

$$T_1 = \dots\dots\dots [3]$$

- (c) Remove the metre rule from the pin. Move the masses so that they are each side of the rule with their bottom edges at the 50.0 cm mark. Replace the metre rule on the pin using the hole at the 10.0 cm mark.

- (i) The time for 10 complete oscillations is t_2 . Take measurements to determine an accurate value of t_2 .

$$t_2 = \dots\dots\dots$$

- (ii) Calculate the time T_2 for one complete oscillation.

$$T_2 = \dots\dots\dots [1]$$

[Total: 5]

[Turn over

3 In this experiment, you will investigate an effect of the refraction of light using water.

You are provided with

- a glass beaker,
- a supply of water,
- a block with a white face,
- an optical pin in a cork,
- a stand, boss and clamp to hold the optics pin,
- a half-metre rule,
- a set square,
- paper towels to mop up spillages.

(a) The beaker has a horizontal line, labelled M, near the top. Using the half-metre rule, determine an average value for the internal distance h from the base of the beaker to line M.

$h = \dots\dots\dots$ [1]

(b) Place the empty beaker on top of the white face of the block. Fill the beaker to the line M with water. Clamp the optical pin horizontally close to line M as shown in Fig. 3.1. Turn the beaker so that the line on the base of the beaker is aligned with the optical pin as shown in Fig. 3.2.

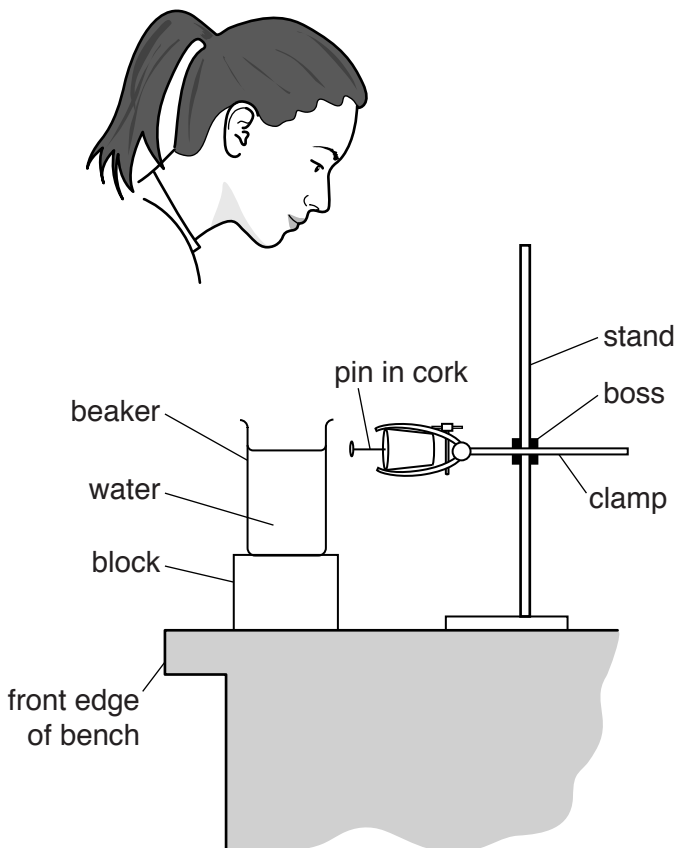

Fig. 3.1

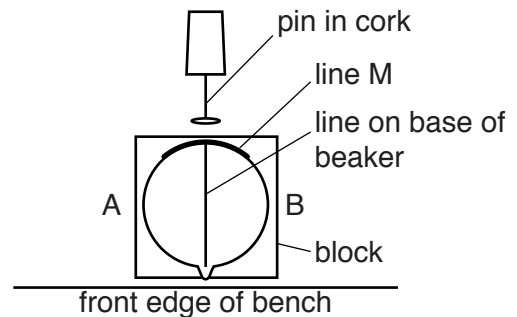

Fig. 3.2

- (c) View the arrangement from vertically above. Move your head from side to side in a direction along a line between A and B. Observe what happens to the alignment of the pin and the line drawn on the base of the beaker. Draw and label diagrams of what you see, at A, at a point directly above the line on the beaker and at B.

at A

**directly above
the line**

at B

[2]

- (d) Lower the pin until the pin and the line on the bottom of the beaker stay in line as you move your head from side to side along AB.

Determine an average value for the vertical distance d from the pin to the surface of the water.

$d = \dots\dots\dots$ [1]

- (e) Calculate $\frac{h}{d}$.

$\frac{h}{d} = \dots\dots\dots$ [1]

[Total: 5]

Section B begins on page 9

Section B

4 In this experiment, you will investigate an electrical circuit.

You have been provided with an incomplete circuit consisting of

- a power supply,
- a switch,
- an unknown resistor labelled X,
- a voltmeter,
- connecting leads.

Two points in the circuit have been labelled A and B. Fig. 4.1 shows the arrangement of the components in the incomplete circuit.

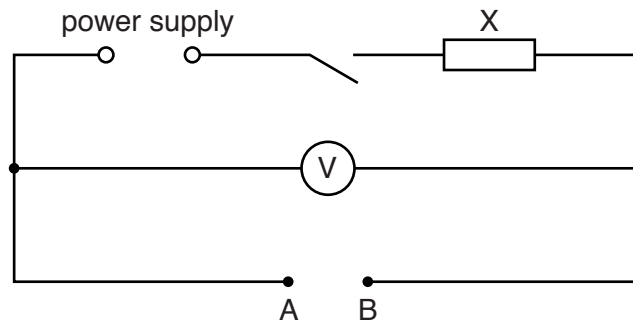

Fig. 4.1

You have also been provided with

- additional connecting leads,
- three resistors labelled with the values of their resistance.

(a) Without changing the circuit, close the switch and record the reading V_0 on the voltmeter.

$$V_0 = \dots\dots\dots [1]$$

(b) Open the switch. Connect the resistor of resistance $R = 10\Omega$ between points A and B.

(i) Close the switch and record the reading V on the voltmeter.

$$V = \dots\dots\dots [1]$$

(ii) Open the switch. Calculate the current I in the circuit using $I = \frac{V}{R}$.

$$I = \dots\dots\dots [1]$$

- (c) Each time you take a reading on the voltmeter, close the switch and open it after you have taken your reading.
- (i) Fig. 4.2 is a table for your results and calculations. Add units to the headings in the table. Transfer your values for R , V and I from (b) into the table.
 - (ii) Remove the $10\ \Omega$ resistor from the circuit and replace it with the $22\ \Omega$ resistor. Record the new reading V in Fig. 4.2. Calculate the new current I in the circuit and record it in Fig. 4.2 along with the resistance R used.
 - (iii) Replace the $22\ \Omega$ resistor with the $39\ \Omega$ resistor and obtain new values for V and I . Record these in Fig. 4.2 along with the resistance R used.
 - (iv) Remove the $39\ \Omega$ resistor.
For two resistors in series $R_{\text{total}} = R_1 + R_2$.
Calculate three possible values of resistance that can be obtained by connecting the $10\ \Omega$, the $22\ \Omega$ and the $39\ \Omega$ resistors in series. Record these values in Fig. 4.2. For each of your values, obtain values for V and I and record these in Fig. 4.2.
 - (v) For two resistors in parallel $\frac{1}{R_{\text{total}}} = \frac{1}{R_1} + \frac{1}{R_2}$.
Calculate the resistance of the $10\ \Omega$ and $22\ \Omega$ resistors when they are connected in parallel and record your value in Fig. 4.2. For this parallel combination, obtain values of V and I and record your values in Fig. 4.2.

R	V	I

Fig. 4.2 [5]

- (d) Using the grid opposite, plot a graph of V on the y -axis against I on the x -axis. Start your axes at the origin. Draw a straight line of best fit. [4]

Question 4 continues on page 12

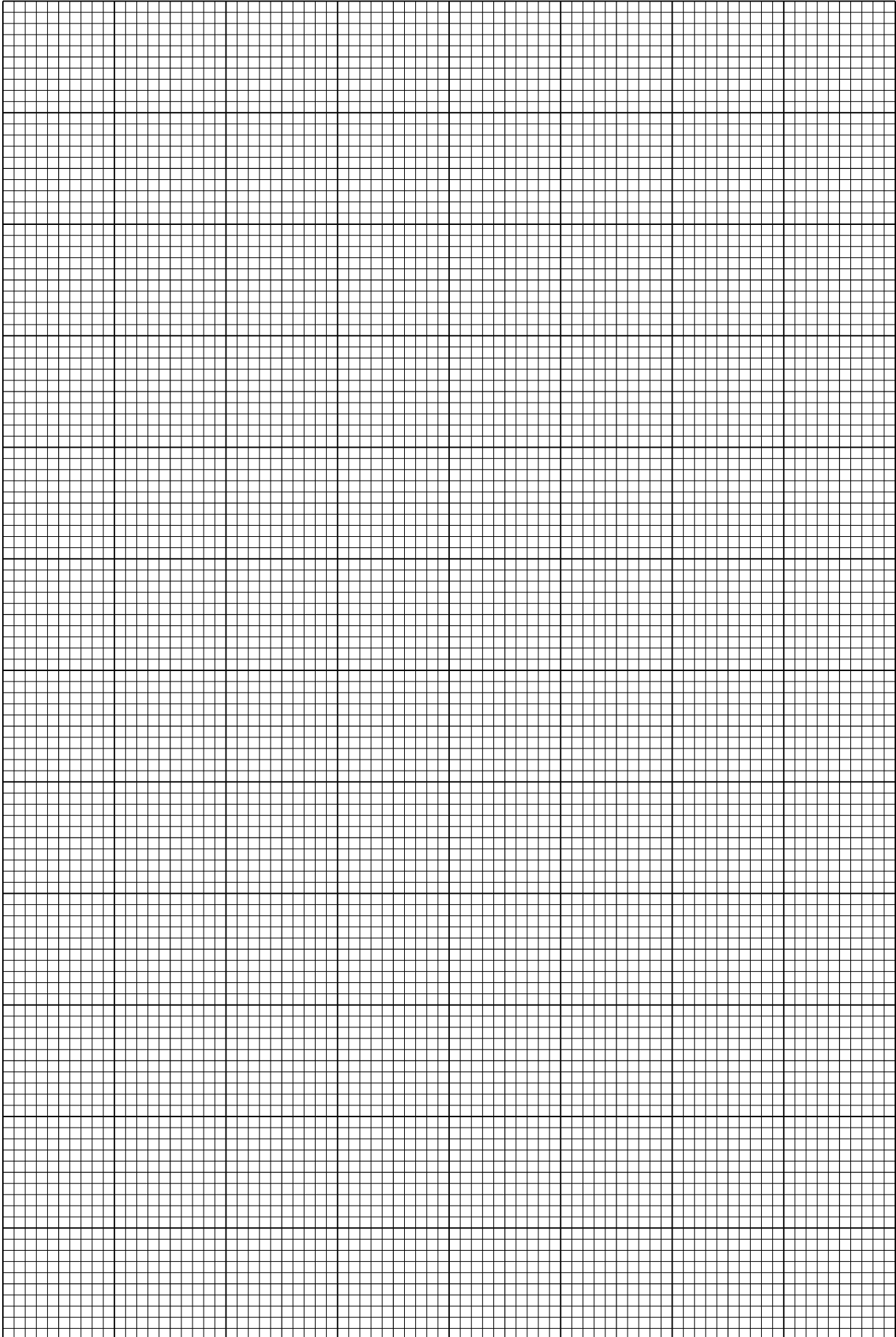

- (e) (i) Determine the gradient G of the line of best fit. Show your working.

$$G = \dots\dots\dots$$

- (ii) Use your graph to find the value of V at $I = 0$.

$$V = \dots\dots\dots [3]$$

[Total: 15]

Permission to reproduce items where third-party owned material protected by copyright is included has been sought and cleared where possible. Every reasonable effort has been made by the publisher (UCLES) to trace copyright holders, but if any items requiring clearance have unwittingly been included, the publisher will be pleased to make amends at the earliest possible opportunity.

To avoid the issue of disclosure of answer-related information to candidates, all copyright acknowledgements are reproduced online in the Cambridge International Examinations Copyright Acknowledgements Booklet. This is produced for each series of examinations and is freely available to download at www.cie.org.uk after the live examination series.

Cambridge International Examinations is part of the Cambridge Assessment Group. Cambridge Assessment is the brand name of University of Cambridge Local Examinations Syndicate (UCLES), which is itself a department of the University of Cambridge.